

Reach truck 1.4 -1.6 ton



BT reflex

*N-series
Coldstore*

RRE140HNC/CC
RRE160HNC/CC



Reach truck, Coldstore version

Identification	1.1	Manufacturer			Toyota	Toyota	Toyota	Toyota
	1.2	Model			RRE140HNC	RRE140HNCC	RRE160HNC	RRE160HNCC
		Type of cabin			Open coldstore	Closed heated	Open coldstore	Closed heated
	1.3	Drive			Electric	Electric	Electric	Electric
	1.4	Operator type			Seated	Seated	Seated	Seated
	1.5	Load capacity/rated load	Q	kg	1400	1400	1600	1600
	1.6	Load centre	c	mm	600	600	600	600
	1.8	Load distance, centre of support arm wheel to face of fork	x	mm	341 *)	260 *)	341*)	260 *)
	1.9	Wheelbase	y	mm	1342	1342	1342	1342
Weight	2.1	Service weight including battery		kg	2635	3473	2635	3473
	2.3	Axle load, mast retracted without load, drive/support arm wheel		kg	1953/1237	2077/1396	1953/1237	2077/1396
	2.4	Axle load, mast extended with load, drive/support arm wheel		kg	575/4011	784/4086	453/4332	801/4269
Wheels	2.5	Axle load, mast retracted with load, drive/support arm wheel		kg	1627/2960	1692/3179	1568/3219	1626/3444
	3.1	Drive/support arm wheel			Polyurethane	Polyurethane	Polyurethane	Polyurethane
	3.2	Wheel size, front		mm	ø343x140	ø343x140	ø343x140	ø343x140
	3.3	Wheel size, rear		mm	ø250x85	ø250x85	ø250x85	ø250x85
	3.5	Wheels, number front/rear (x = driven wheels)			1x/2	1x/2	1x/2	1x/2
	3.7	Track width, rear	b ₁₁	mm	988	988	988	988
Dimensions	4.1	Tilt of fork, forward/backward	α/β	deg	-2°/ 4° *)	-2°/ 4° *)	-2°/ 4° *)	-2°/ 4° *)
	4.2	Height, mast lowered	h ₁	mm	2887 *)	2887 *)	2887 *)	2887 *)
	4.3	Free lift	h ₂	mm	2403 *)	2403 *)	2403 *)	2403 *)
	4.4	Lift	h ₃	mm	6945 *)	6945 *)	6945 *)	6945 *)
		Lift height	h ₂₃	mm	7000 *)	7000 *)	7000 *)	7000 *)
	4.5	Height, mast extended	h ₄	mm	7540 *)	7540 *)	7540 *)	7540 *)
	4.7	Height of overhead guard (cabin)	h ₆	mm	2198	2200	2198	2200
	4.8	Seat height	h ₇	mm	1136	1136	1136	1136
	4.10	Height support arms	h ₈	mm	270	270	270	270
	4.15	Height, fork lowered	h ₁₃	mm	55	55	55	55
	4.19	Overall length	l ₁	mm	2413	2557	2413	2557
	4.20	Length to face of forks	l ₂	mm	1263	1407	1263	1407
	4.21	Overall width	b ₁	mm	1120	1120	1120	1120
	4.22	Fork dimensions	s/e/l	mm	40/100/1150 *)	40/100/1150 *)	40/100/1150 *)	40/100/1150 *)
	4.23	Fork carriage ISO 2328, class/type A, B			2A	2A	2A	2A
	4.24	Fork carriage width	b ₃	mm	819	819	819	819
	4.25	Width over forks	b ₅	mm	252-698	252-698	252-698	252-698
	4.26	Distance between wheel arms/loading surfaces	b ₄	mm	900	900	900	900
	4.28	Reach distance	l ₄	mm	503 *)	431 *)	503 *)	431 *)
	4.31	Ground clearance, with load, below mast	m ₁	mm	68	68	68	68
4.32	Ground clearance, center of wheelbase (15 mm under studs)	m ₂	mm	74	74	74	74	
4.34.1	Aisle width for pallets 1000x1200 crossways	A _{st}	mm	2695	2820	2695	2820	
4.34.2	Aisle width for pallets 800x1200 lengthways	A _{st}	mm	2751	2889	2751	2889	
4.35	Turning radius	W _a	mm	1604	1667	1604	1667	
4.37	Length across support arms	l ₇	mm	1747	1810	1747	1810	
Performance data	5.1	Travel speed, with/without load		km/h	10/11	10/11	10/11	10/11
	5.1	Travel speed, with/without load (High speed version)		km/h	10/14	10/14	10/14	10/14
	5.2	Lift speed, with/without load		m/s	0,38/0,68	0,36/0,68	0,36/0,68	0,36/0,68
		Lift speed, with/without load (High speed version) ¹⁾		m/s	0,57/0,92	0,57/0,92	0,52/0,92	0,52/0,92
	5.3	Lowering speed, with/without load		m/s	0,55/0,59	0,55/0,59	0,55/0,59	0,55/0,59
	5.4	Reach speed, with/without load		m/s	0,20/0,28	0,20/0,28	0,20/0,28	0,20/0,28
	5.8	Max. gradeability, with/without load ²⁾		%	10/15	10/15	10/15	10/15
	5.9	Acceleration time with/without load (over 10 m)		s	4,9/4,6	-	5,0/4,6	-
	Acceleration time with/without load (over 10 m) (High speed version)		s	4,9/4,7	-	5,0/4,6	-	
5.10	Service brake			Electric	Electric	Electric	Electric	
Electric	6.1	Drive motor rating S2 60 min		kW	9	9	9	9
	6.2	Lift motor rating S3 15%		kW	11,0	11,0	11,0	11,0
		Lift motor rating S3 15% (High speed version)		kW	15,0	15,0	15,0	15,0
	6.4	Battery voltage, nominal capacity K _s		V/Ah	48/310 *)	48/465 *)	48/310 *)	48/465 *)
	6.5	Battery weight		kg	510	685	510	685
Other	8.1	Type of drive control			Variable AC	Variable AC	Variable AC	Variable AC
	8.4	Sound level at the driver's ear according to EN 12 053		dB(A)	64	64	64	64

1) Not in combination with lead acid battery 310 Ah

2) Measured according to company standard

*) Other alternatives are available

All data are based on table configuration. Other configurations may give other values.

Truck performance and dimensions are nominal and subject to tolerances.

Toyota Material Handling products and specifications are subject to change without notice.

Battery dependent dimensions

Dimensions				RRE140HNC			RRE140HNCC		RRE160HNC			RRE160HNCC	
	Battery compartment		mm	275	347	419	347	419	275	347	419	347	419
1.8	Load distance, centre of support arm wheel to face of forks	x	mm	341 ¹⁾	269 ¹⁾	190	260	188	341 ¹⁾	269 ¹⁾	190	260	188
4.20	Length to face of forks	l_2	mm	1263 ²⁾	1335 ²⁾	1425	1407	1479	1263 ²⁾	1335 ²⁾	1425	1407	1479
4.34.1	Aisle width for pallets 1000x1200 crossways	A_{st}	mm	2695 ²⁾	2750 ²⁾	2812	2820	2877	2695 ²⁾	2750 ²⁾	2812	2820	2877
4.34.2	Aisle width for pallets 800x1200 lengthways	A_{st}	mm	2751 ²⁾	2817 ²⁾	2890	2889	2955	2751 ²⁾	2817 ²⁾	2890	2889	2955
4.35	Turning radius	W_a	mm	1604	1604	1604	1667	1667	1604	1604	1604	1667	1667
6.4	Battery voltage, nominal capacity, Lead-Acid	K_5	V/Ah	48/310	48/465	48/620	48/465	48/620	48/310	48/465	48/620	48/465	48/620
	Battery voltage, nominal capacity, Li-Ion	K_5	V/Ah	---	48/300-420	48/300-420	48/300-420	48/300-420	---	48/300-420	48/300-420	48/300-420	48/300-420
6.5	Battery weight, min.—max.		kg	510-609	685-825	875-1030	685-825	875-1030	510-609	685-825	875-1030	685-825	875-1030

1) With battery in sleigh -9 mm

2) With battery in sleigh +9 mm

Mast dimensions

RRE140/160HNC/HNCC			Triplex Hi-Lo - A												
	Lift height	h_{23}	mm	4900	5400	5700	6300	7000	7250	7500	8000	8500	9000	9500	10000
4.4	Lift	h_3	mm	4845	5345	5645	6245	6945	7195	7445	7945	8445	8945	9445	9945
4.2	Height, mast lowered	h_1	mm	2187	2354	2454	2654	2887	2971	3054	3221	3387	3554	3721	3887
4.3	Free lift	h_2	mm	1703	1871	1971	2171	2403	2487	2571	2737	2903	3071	3237	3403
4.5	Height, mast extended	h_4	mm	5440	5941	6241	6841	7540	7792	8041	8542	9040	9541	10042	10540

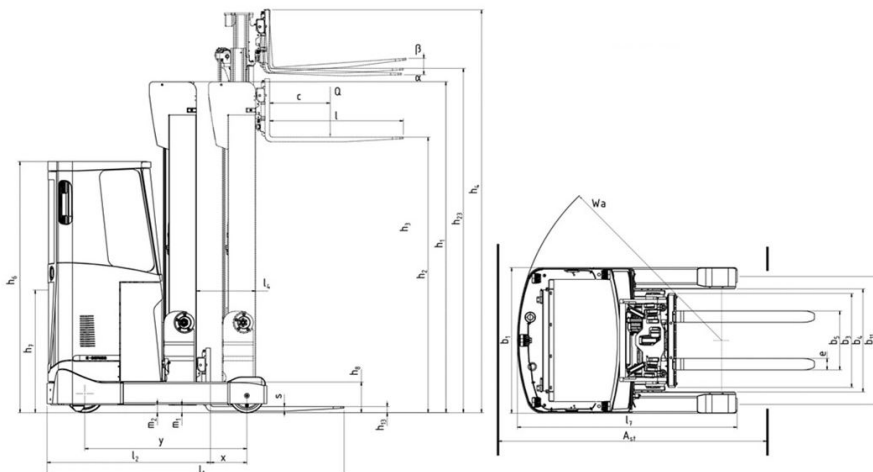
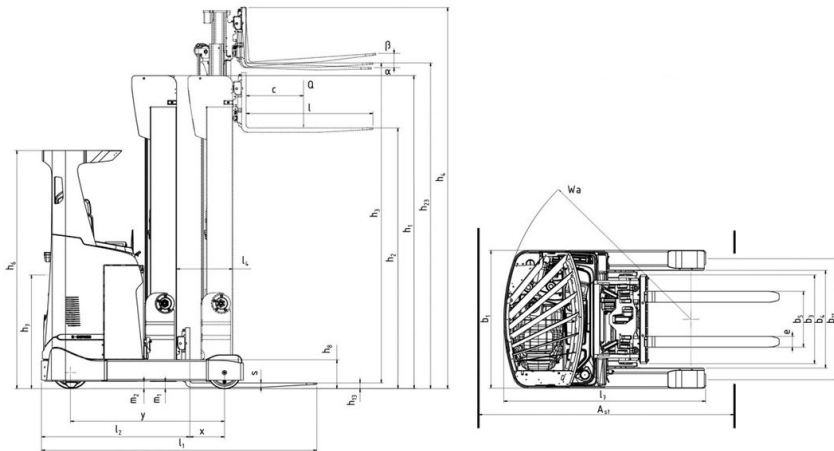



TMHE-Toyota Material Handling Europe — version 3, 2023-04-25

TOYOTA

MATERIAL HANDLING