

# Hand pallet truck 0.75 ton

## BT lifter

*L-series*

LHM075H



# Hand pallet truck

Truck specifications					LHM075H
Identification	1.1	Manufacturer			Toyota
	1.2	Manufacturer's type designation			LHM075H
		Fork length		mm	950
	1.4	Operator type			Hand
	1.5	Load capacity/rated load	Q(t)	kg	750
	1.6	Load centre distance	c	mm	400
	1.8	Load distance, centre of drive axle to fork	x	mm	745 <sup>1)</sup>
	1.9	Wheelbase	y	mm	1170 <sup>1)</sup>
Weight	2.1	Service weight		kg	58
	2.2	Axle load, with load, drive/castor/fork wheel		kg	120/260
	2.3	Axle load, without load, drive/castor/fork wheel		kg	20-10
Wheels	3.1	Steer/fork/support wheels: Powerthane (Po), Steel (S) Nylon (N), Polyurethane (P), Rubber (R), Rubber antistatic (Ra)			P
	3.2	Wheel size, front			175x60
	3.3	Wheel size, rear			85x75
	3.5	Wheels, number front/rear (x = driven wheels)			2/2
	3.6	Track width, front	$b_{10}$	mm	132
	3.7	Track width, rear	$b_{11}$	mm	340
	Dimensions	4.4	Lift	$h_3$	mm
		Lift height	$h_{23}$	mm	200
4.9		Height of tiller in drive position, min./max.	$h_{14}$	mm	1220
4.15		Height, lowered	$h_{13}$	mm	85
4.19		Overall length	$l_1$	mm	1500
4.20		Length to face of forks	$l_2$	mm	365
4.21		Overall width	$b_1$	mm	520
4.22		Fork dimensions	s/e/l	mm	45/110/950
4.25		Width over forks	$b_5$	mm	450
4.32		Ground clearance, centre of wheelbase	$m_2$	mm	40
4.33		Aisle width for pallets 1000x1200 crossways	$A_{st}$	mm	1544 <sup>1)</sup>
4.34		Aisle width for pallets 800x1200 lengthways	$A_{st}$	mm	1544 <sup>1)</sup>
4.35		Turning radius	$W_a$	mm	1175 <sup>1)</sup>

1) Distance with forks raised.

All data are based on table configuration. Other configurations may give other values.  
 Truck performance and dimensions are nominal and subject to tolerances.  
 Toyota Material Handling products and specifications are subject to change without notice.

# Dimensional drawings

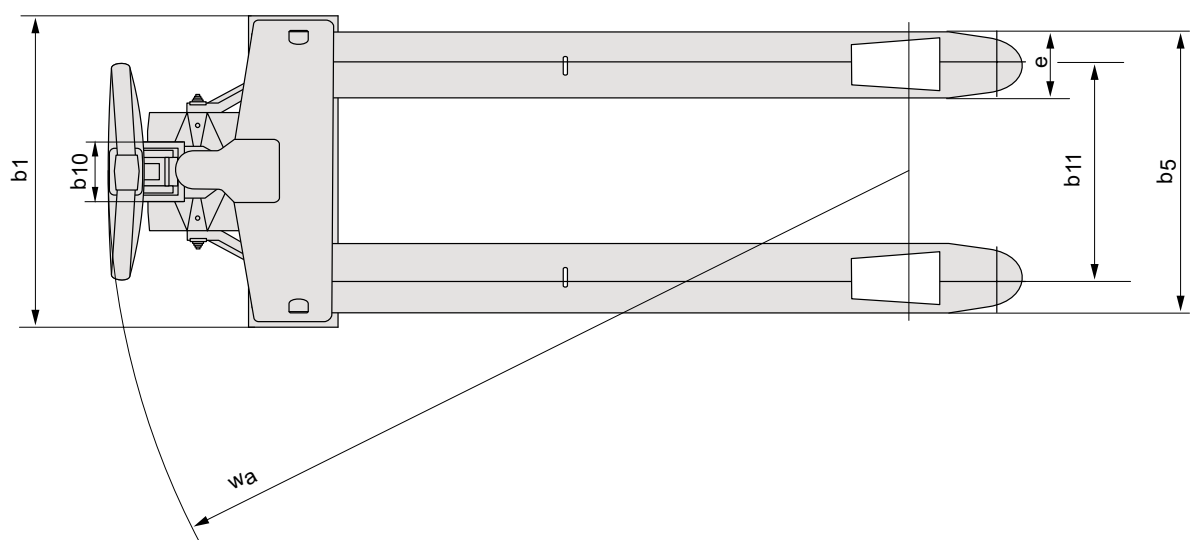
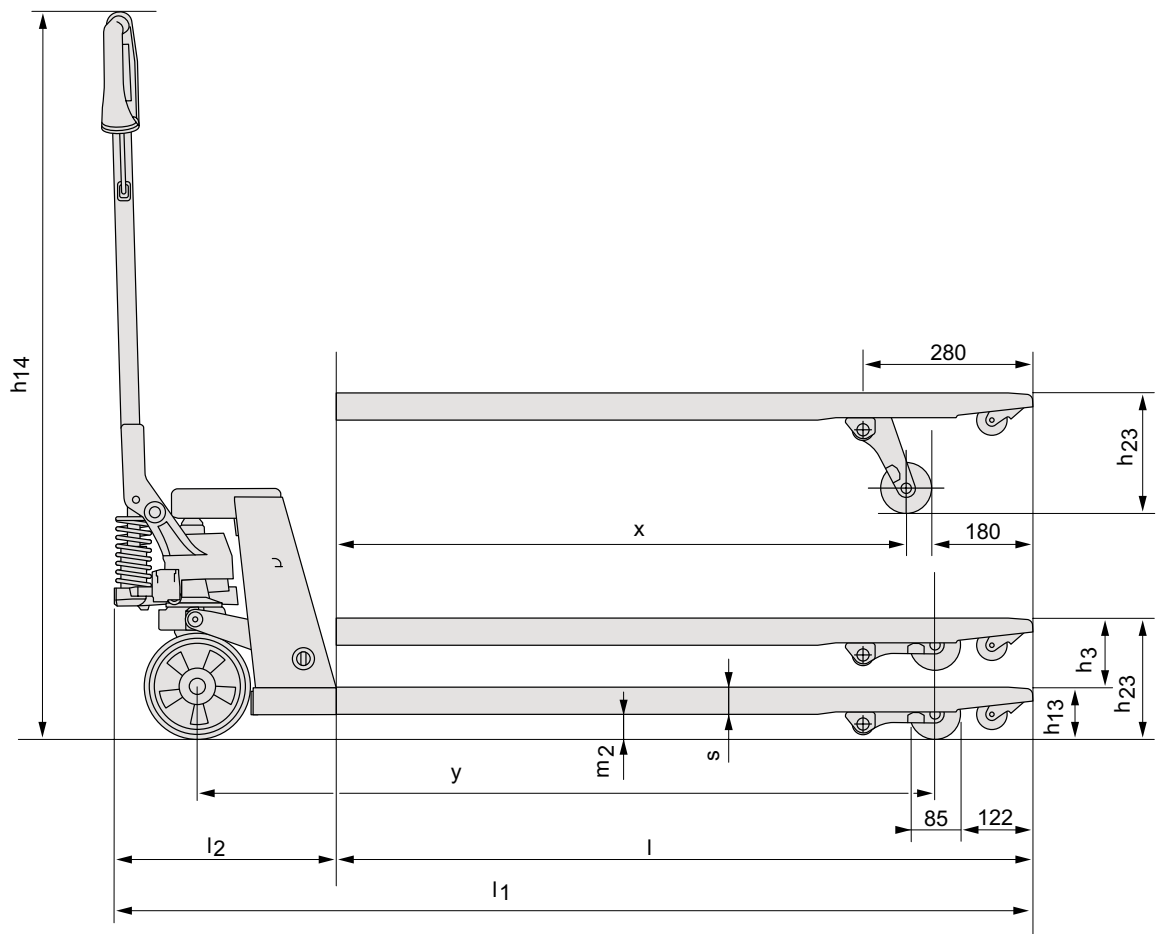

---

## Truck features:

- This BT Lifter has been specially adapted for handling of different types of half pallets.
- Robust design and still low weight – easy to manoeuvre.
- Powder coating and robot welding give a high and even finish.
- Angled high strength polymer handle for best ergonomic grip.
- BT lowering control valve enables smooth, controlled lowering action.
- Strong powerful thrust bearing is standard, for easier steering and enhanced durability.
- Greasable bushings ensure long service life.
- Quick lift and overload can be combined.
- Customized configurations – a part of our offer.



TMHE-Toyota Material Handling Europe , version 2, 2025-05-26

**TOYOTA**

MATERIAL HANDLING