

Hand pallet truck 2.0 ton



BT lifter

L-series

LHM200L/Z



Hand pallet truck

Truck specifications					LHM200L	LHM200Z
Identification	1.1	Manufacturer			Toyota	Toyota
	1.2	Manufacturer's type designation			LHM200L	LHM200Z
	1.4	Operator type			Hand	Hand
	1.5	Load capacity/rated load	Q(t)	kg	2000	2000
	1.6	Load centre distance	c	mm	600	600
	1.8	Load distance, centre of drive axle to fork	x	mm	945 ¹⁾	945 ¹⁾
	1.9	Wheelbase	y	mm	1170 ¹⁾	1170 ¹⁾
Weight	2.1	Service weight		kg	63	63
	2.2	Axle load, with load, drive/castor/fork wheel		kg	315/716	315/716
	2.3	Axle load, without load, drive/castor/fork wheel		kg	20/10	20/10
Wheels	3.1	Steer/fork wheels: Powerthane (Po), Steel (S) Nylon (N), Polyurethane (P), Rubber (R), Rubber antistatic (Ra)			S, N / S, N	Po, S, N, P, R, Ra / N
	3.2	Wheel size, front			140x60	175x60
	3.3	Wheel size, rear			55x100/55x75 ²⁾	65x100
	3.5	Wheels, number front/rear (x = driven wheels)			2/2 or 2/4 ²⁾	2/2
	3.6	Track width, front	b ₁₀	mm	132	132
	3.7	Track width, rear	b ₁₁	mm	364	364
Dimensions	4.4	Lift	h ₃	mm	70	115
		Lift height	h ₂₃	mm	125	180
	4.9	Height of tiller in drive position, min./max.	h ₁₄	mm	1202	1220
	4.15	Height, lowered	h ₁₃	mm	55	65
	4.19	Overall length	l ₁	mm	1500	1500
	4.20	Length to face of forks	l ₂	mm	365	365
	4.21	Overall width	b ₁ /b ₂	mm	520/685 ³⁾	520/685 ³⁾
	4.22	Fork dimensions	s/e/l	mm	45/156/1150 ⁴⁾	45/156/1150 ⁴⁾
	4.25	Width over forks	b ₅	mm	520/685 ³⁾	520/685 ³⁾
	4.32	Ground clearance, centre of wheelbase	m ₂	mm	10	20
	4.33	Aisle width for pallets 1000x1200 crossways	A _{st}	mm	1525 ¹⁾	1525 ¹⁾
	4.34	Aisle width for pallets 800x1200 lengthways	A _{st}	mm	1725 ¹⁾	1725 ¹⁾
4.35	Turning radius	W _a	mm	1370 ¹⁾	1370 ¹⁾	

1) Distance with forks raised.

2) Singel wheel/Boggie wheel.

3) Other widths available on request.

4) Other fork lenght available: 800/910/1000/1070/1220

All data are based on table configuration. Other configurations may give other values.

Truck performance and dimensions are nominal and subject to tolerances.

Toyota Material Handling products and specifications are subject to change without notice.

Dimensional drawings

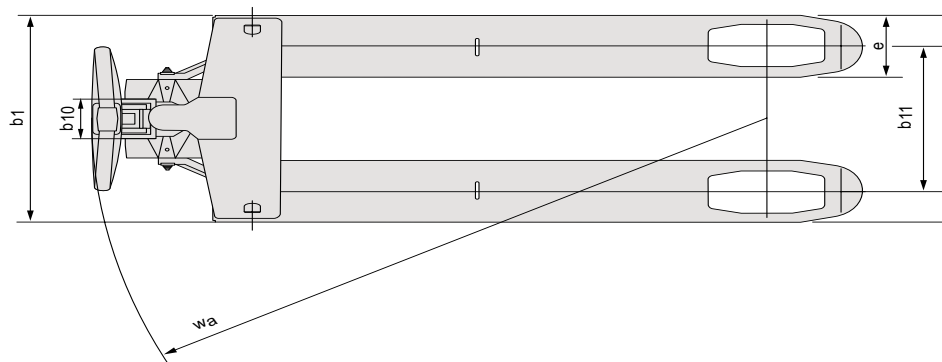
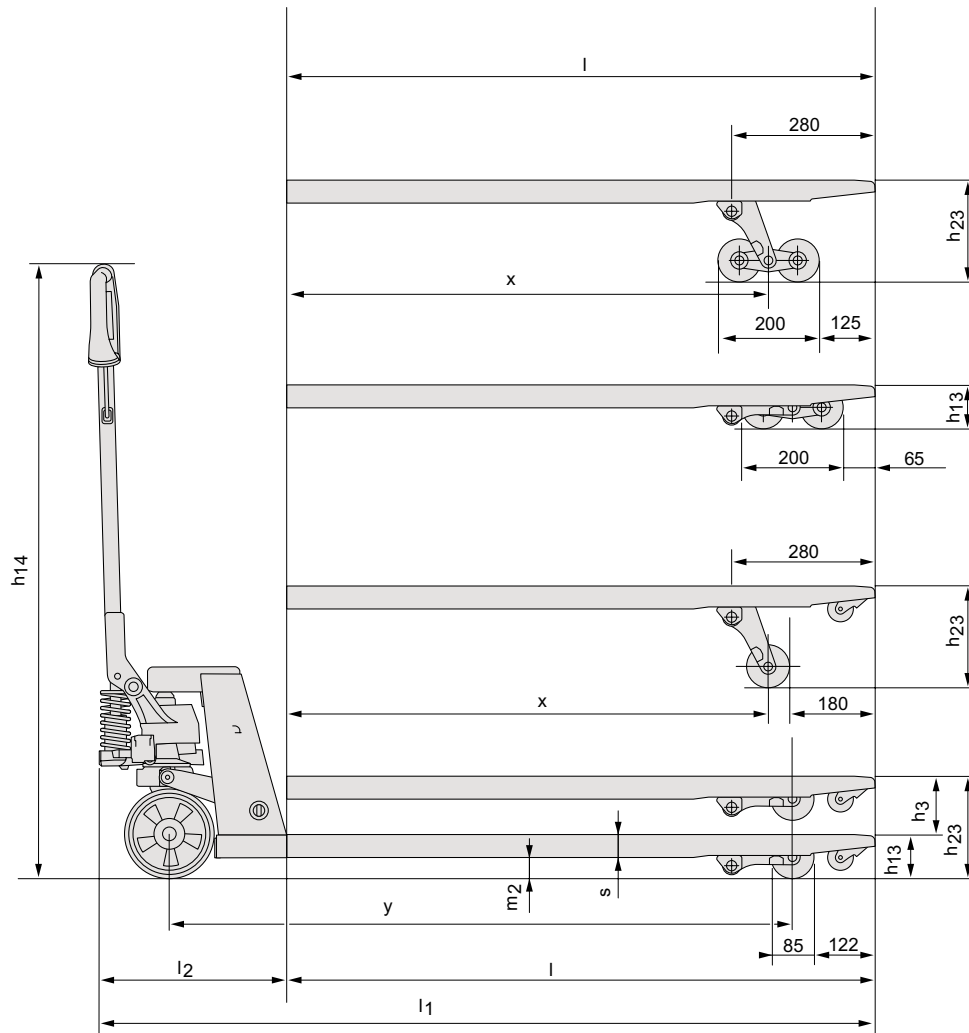

Truck features:

- Robust design and still low weight – easy to manoeuvre.
- Powder coating and robot welding give a high and even finish.
- Angled high strength polymer handle for best ergonomic grip.
- BT lowering control valve enables smooth, controlled lowering action.
- Strong powerful thrust bearing is standard, for easier steering and enhanced durability.
- Greasable bushings ensure long service life.
- Quick lift and overload can be combined.
- This product has been environmentally declared and is certified to ISO 14020.
- Customized configurations – a part of our offer.



TMHE-Toyota Material Handling Europe – 745353-040, version 3, 2026-03-31

TOYOTA

MATERIAL HANDLING