

Pedestrian lowlifter truck 2.0 ton

BT levio

P-series

LPE200I



Pedestrian lowlifter

Specification for lowlifter trucks					LPE200I
Identification	1.1	Manufacturer			Toyota
	1.2	Model			LPE200I
	1.3	Drive			Electric
	1.4	Operator type			Pedestrian
	1.5	Load capacity/rated load	Q	kg	2000
	1.6	Load centre	c	mm	600
	1.8	Load distance, centre of support arm wheel to face of forks	x	mm	947
	1.9	Wheelbase forks lifted/lowered	y	mm	1321/1400
	Weight	2.1	Service weight without battery		kg
2.2		Axle load, with load, drive/castor/fork wheel		kg	554/556/1651
2.3		Axle load, without load, drive/castor/fork wheel		kg	334/269/150
Wheels	3.1	Drive/castor/fork wheel			Polyurethane
	3.2	Wheel size, front	Ø	mm	230x75
	3.3	Wheel size, rear	Ø	mm	85x95
	3.4	Additional wheels (dimensions)	Ø	mm	125x50
	3.5	Wheels, number front/rear (x = driven wheels)			1x+2/2
	3.6	Track width, front	b ₁₀	mm	580
	3.7	Track width, rear	b ₁₁	mm	340/390/505
Dimensions	4.4	Lift	h ₃	mm	140
		Lift height	h ₂₃	mm	225
	4.8	Stand height	h ₇	mm	180
	4.9	Height of tiller in drive position, min./max.	h ₁₄	mm	1100/1313
	4.15	Height, fork lowered	h ₁₃	mm	85
	4.19	Overall length platform folded up/down	l ₁	mm	1852/2230
	4.20	Length to face of forks platform folded up/down	l ₂	mm	702/1080
	4.21	Overall width	b ₁	mm	790
	4.22	Fork dimensions	s/e/l	mm	77/150/1150
	4.25	Width over forks	b ₅	mm	490/540/655
	4.32	Ground clearance, centre of wheelbase	m ₁	mm	39
	4.33	Aisle width for pallets 1000x1200 crossways	A _{st}	mm	2493
	4.34	Aisle width for pallets 800x1200 lengthways	A _{st}	mm	2308
	4.35	Turning radius platform folded up/down	W _a	mm	1660/2033
Performance data	5.1	Travel speed, with/without load		km/h	6,0/6,0
	5.2	Lift speed, with/without load		m/s	0,05/0,07
	5.3	Lowering speed, with/without load		m/s	0,08/0,07
	5.8	Max. gradeability, with/without load		%	8/18
	5.10	Service brake			Electric
Electric motor	6.1	Drive motor rating S2 60 min		kW	2,5
	6.2	Lift motor rating at S3 10%		kW	2,2
	6.4	Battery voltage/nominal capacity K _s		V/Ah	24/240
	6.5	Battery weight		kg	175/275
Others	8.1	Type of drive control			Variable AC
	8.4	Sound level at the driver's ear acc to EN12 053		dB(A)	66
		Full body vibration value according to EN 13059 and EN 12096, margin of error 30 %		m/s ²	0,33

All data are based on table configuration. Other configurations may give other values.

Truck performance and dimensions are nominal and subject to tolerances.

Toyota Material Handling Manufacturing Sweden AB products and specifications are subject to change without notice.

Dimensions

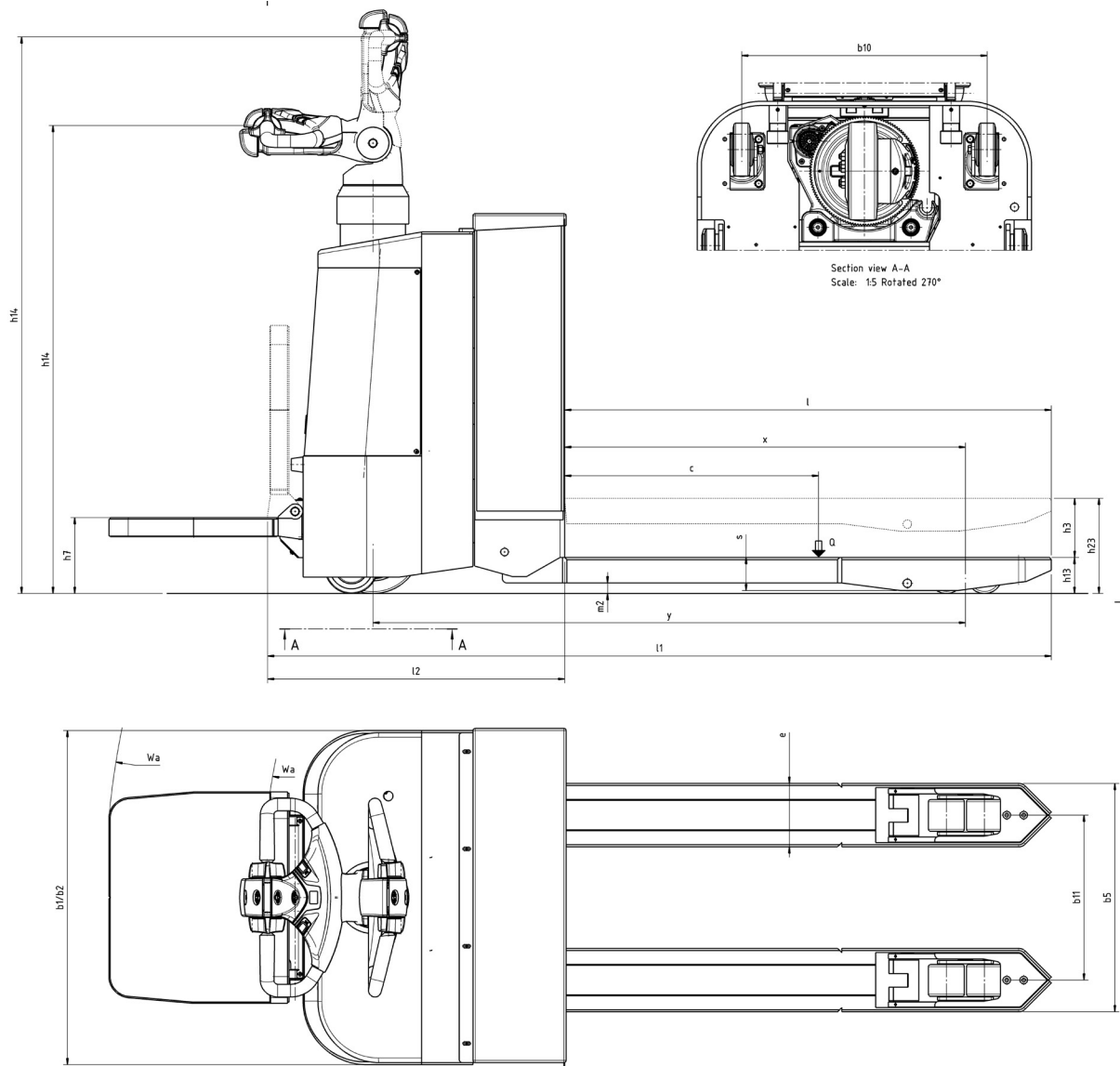

Truck features:

- AC drive motor
- BT Powertrak traction system
- Readily accessible controls
- Electronic braking system
- Operator safety
- Automatic switch-off
- Programmable performance
- Easy access for maintenance
- Flip-up operator platform
- Power steering
- Click-2-creep

